

ROHS REACH

日期版次 REVISION	日期 DATE	变更内容 DESCRIPTION	核准 APPROVALBY

SPECIFICATIONS

- Voltage rating: 250V DC/AC (rms)
- Current rating: 3.0A
- Withstand voltage: 1000V AC(rms)
- Working Temperature: -25°C +85°C
- Insulation resistance: ≥1000MΩ
- Contact resistance: ≤20MΩ

HOUSING

- PART NO: A2502H
- MATERIAL: NYLON66 94V-0
- COLOR: NATURAL(WHITE)
- USE WITH:
Terminal: A2501T
Wafer: A2502R A2502V
- Q'TY: 1000PCS/BAG

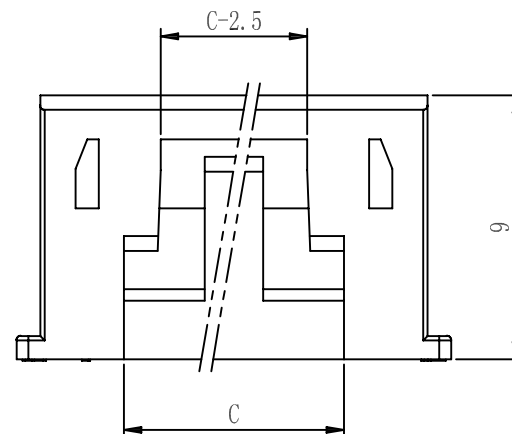
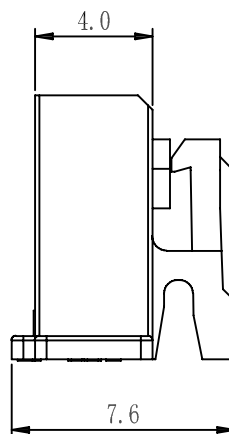
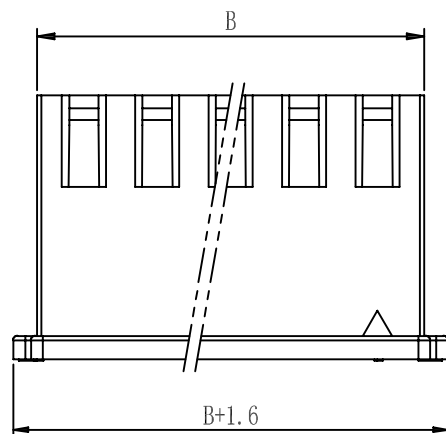
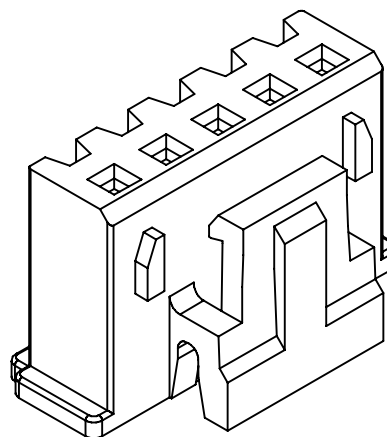
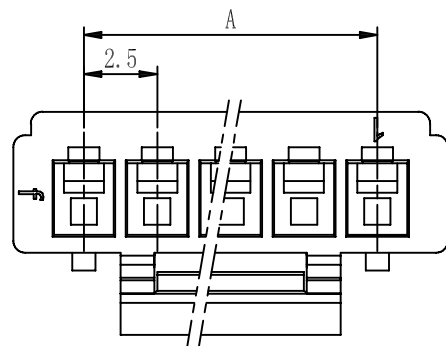

poles	part no.	dimensions (mm)		
		A	B	C
2	A2502H-2P	2.50	5.70	3.00
3	A2502H-3P	5.00	8.20	4.00
4	A2502H-4P	7.50	10.70	5.00
5	A2502H-5P	10.00	13.20	7.50
6	A2502H-6P	12.50	15.70	10.00
7	A2502H-7P	15.00	18.20	12.50
8	A2502H-8P	17.50	20.70	12.50
9	A2502H-9P	20.00	23.20	12.50
10	A2502H-10P	22.50	25.70	12.50
11	A2502H-11P	25.00	28.20	12.50
12	A2502H-12P	27.50	30.70	12.50
13	A2502H-13P	30.00	33.20	12.50
14	A2502H-14P	32.50	35.70	12.50
15	A2502H-15P	35.00	38.20	12.50
16	A2502H-16P	37.50	40.70	12.50
20	A2502H-20P	47.50	50.70	17.50

MATERIAL: PA66UL94-V0	GENERAL TOLERANCE	
UNIT: MM	X. ±0.30	X.* ±2°
SCALE: 3:1	X.X ±0.25	X.X* ±1°
SIZE: A4	X.XX ±0.15	⊕ ⊖

YETZ 东莞市轩盟电子科技有限公司
DONGGUAN YSTZ ELECTRONIC TECHNOLOGY CO.,LTD

PART NO: A2502H-NP-10D-06

TITLE : 250MM PITCH HOUSING 带扣

REV: A	APPROVE	CHECK	DRAWN
SHEET:1/1	FENG	ZENG	LIJIAN

ROHS REACH

日期版次 REVISION	日期 DATE	变更内容 DESCRIPTION	核 准 APPROVALBY

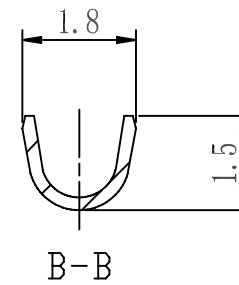
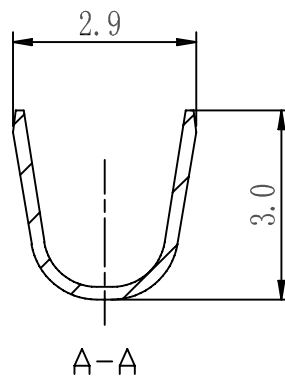
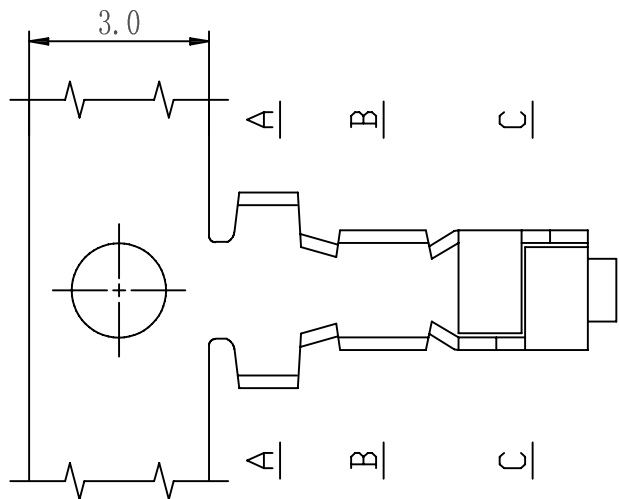
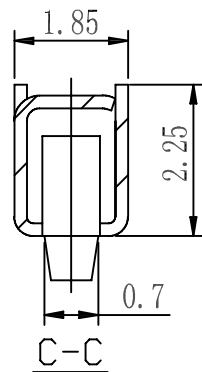
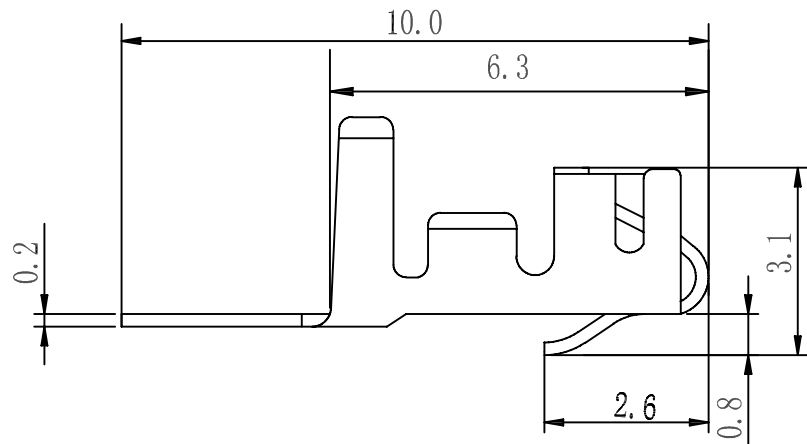

SPECIFICATIONS

- Voltage rating: 250V DC/AC (rms)
- Current rating: 3.0A
- Withstand voltage: 1000V AC(rms)
- Working Temperature: -25°C +85°C
- Insulation resistance: ≥1000MΩ
- Contact resistance: ≤20mΩ

TERMINAL

- PART NO: A2501T
- THICKNESS: 0.20MM
- MATERIAL: PHOSPHOR BRONZE
- FINISH: TIN-PLATED
- APPLICABLE WIRE: AWG#28-#22
- USE WITH: Housing: A2501H A2502H
- Q'TY: 6000PCS/REEL

REV: A	APPROVE	CHECK	DRAWN	MATERIAL:	GENERAL TOLERANCE		东莞市轩盟电子科技有限公司 DONGGUAN YSTZ ELECTRONIC TECHNOLOGY CO.,LTD PART NO: A2501T-PD-1E-06 TITLE : 2.50mm Pitch Terminal
SHEET: 1/1	FENG	ZENG	LIJIAN	UNIT: MM	X. ±0.30	X.* ±2°	
				SCALE: 3:1	X.X ±0.25	X.X* ±1°	
				SIZE: A4	X.XX ±0.15		

ROHS REACH

日期版次 REVISION	日期 DATE	变更内容 DESCRIPTION	核 准 APPROVALBY

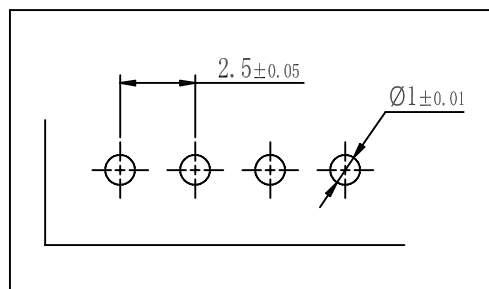
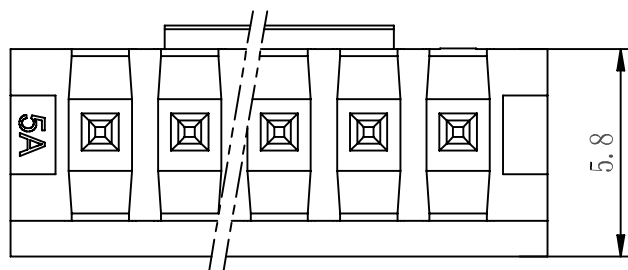
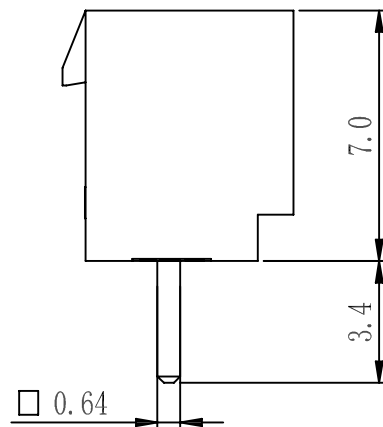
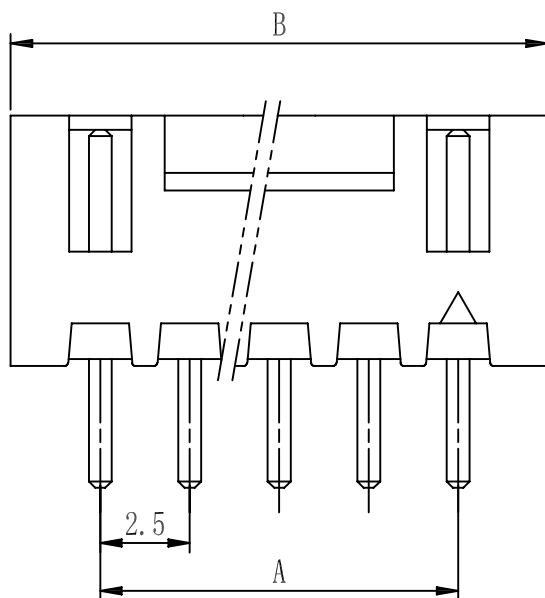

SPECIFICATIONS

- Voltage rating: 250V DC/AC (rms)
- Current rating: 3.0A
- Withstand voltage: 1000V AC(rms)
- Working Temperature: -25℃+85℃
- Insulation resistance: ≥1000MΩ
- Contact resistance: ≤20mΩ

poles	part no.	dimensions (mm)	
		A	B
2	A2502V-2P	2.50	7.50
3	A2502V-3P	5.00	10.00
4	A2502V-4P	7.50	12.50
5	A2502V-5P	10.00	15.00
6	A2502V-6P	12.50	17.50
7	A2502V-7P	15.00	20.00
8	A2502V-8P	17.50	22.50
9	A2502V-9P	20.00	25.00
10	A2502V-10P	22.50	27.50
11	A2502V-11P	25.00	30.00
12	A2502V-12P	27.50	32.50
13	A2502V-13P	30.00	35.00
14	A2502V-14P	32.50	37.50
15	A2502V-15P	35.00	40.00
16	A2502V-16P	37.50	42.50
20	A2502V-20P	47.50	52.50

P. C. BLAYOUT

PIN针	2-16、20	BRASS	TIN-PLATED
壳体	1	PA66 UL 94V-0	BEIGE
PART NAME	QTY.	MATERIALS	SPEC
REV: A	APPROVE	CHECK	DRAWN
SHEET:1/1	FENG	ZENG	LIJIAN

MATERIAL:	GENERAL TOLERANCE	
UNIT: MM	X. ±0.30	X.* ±2°
SCALE: 3:1	X.X ±0.25	X.X* ±1°
SIZE: A4	X.XX ±0.15	⊕ ⊖

YSTZ 东莞市轩盟电子科技有限公司
DONGGUAN YSTZ ELECTRONIC TECHNOLOGY CO.,LTD

PART NO: A2502V-NP-10D-06

TITLE : 2.50mm Pitch 180° Waferl带扣

ROHS REACH

日期版次	日期	变更内容	核 准
REVISION	DATE	DESCRIPTION	APPROVALBY

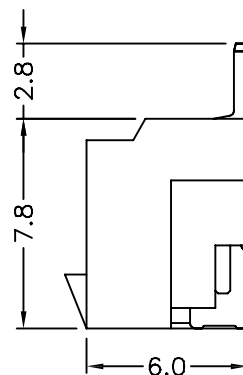
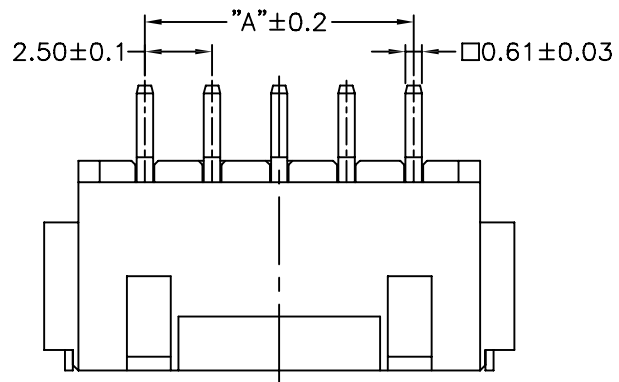

NOTES:

CURRENT RATING: 3A AC/DC.
 VOLTAGE RATING: 250V AC/DC.
 TEMPERATURE RANGE: $-25^{\circ}\text{C} \sim +85^{\circ}\text{C}$.
 CONTACT RESISTANCE: 20mΩ MAX.
 INSULATION RESISTANCE: 1000MΩ MIN.
 WITHSTANDING VOLTAGE: 1000V AC/MINUTE.

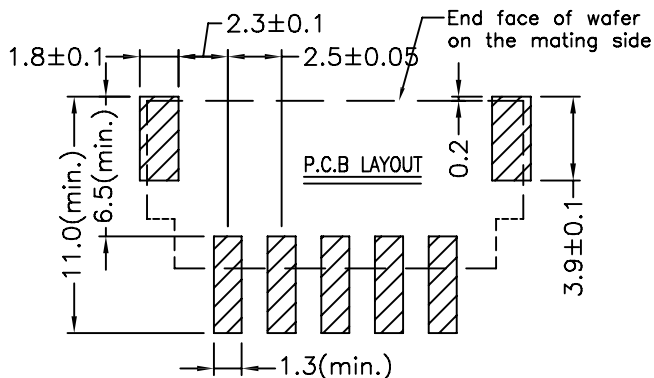
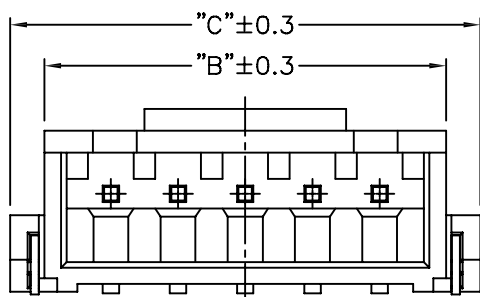

poles	part no	dimensions (mm)		
		A	B	C
2	A2502RS-2P	2.50	7.45	10.00
3	A2502RS-3P	5.00	9.95	12.50
4	A2502RS-4P	7.50	12.45	15.00
5	A2502RS-5P	10.00	14.95	17.50
6	A2502RS-6P	12.50	17.45	20.00
7	A2502RS-7P	15.00	19.95	22.50
8	A2502RS-8P	17.50	22.45	25.00
9	A2502RS-9P	20.00	24.95	27.50
10	A2502RS-10P	22.50	27.45	30.00
11	A2502RS-11P	25.00	29.95	32.50
12	A2502RS-12P	27.50	32.45	35.00
13	A2502RS-13P	30.00	34.95	37.50
14	A2502RS-14P	32.50	37.45	40.00
15	A2502RS-15P	35.00	39.95	42.50
16	A2502RS-16P	37.50	42.45	45.00

定位片	2	Phosphor bronze	TIN-PLATED
PIN针	2-16	BRASS	TIN-PLATED
壳体	1	PA9T UL 94V-0	BEIGE
PART NAME	QTY.	MATERIALS	SPEC
REV: A	APPROVE	CHECK	DRAWN
SHEET:1/1	FENG	ZENG	LIJIAN

MATERIAL:	GENERAL TOLERANCE
UNIT: MM	X. ±0.30 X.* ±2°
SCALE: 3:1	X.X ±0.25 X.X* ±1°
SIZE: A4	X.XX ±0.15

YSTZ 东莞市轩盟电子科技有限公司
 DONGGUAN YSTZ ELECTRONIC TECHNOLOGY CO.,LTD

PART NO: A2502RS-NP-70E-04
 TITLE: XHS2.50mm Pitch 90°-SMT-Wafer