

ROHS REACH

日期版次	日期	变更内容	核准
REVISION	DATE	DESCRIPTION	APPROVAL BY

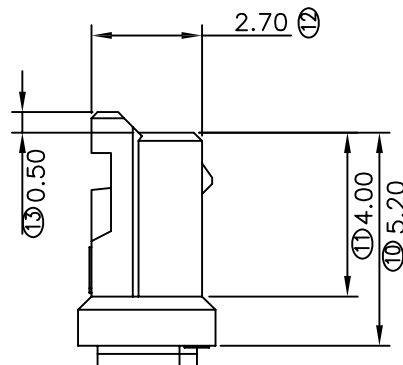
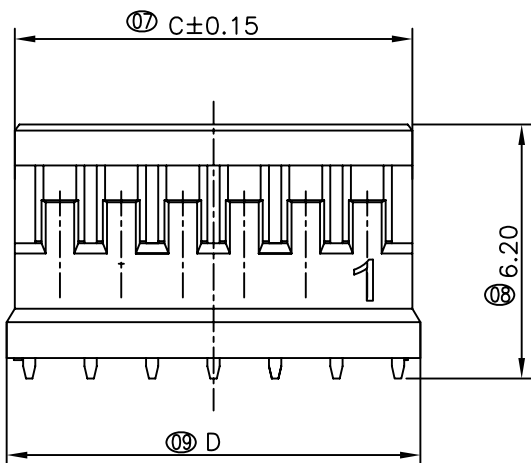
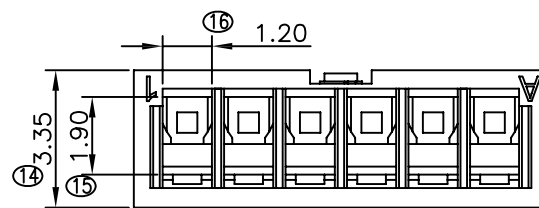
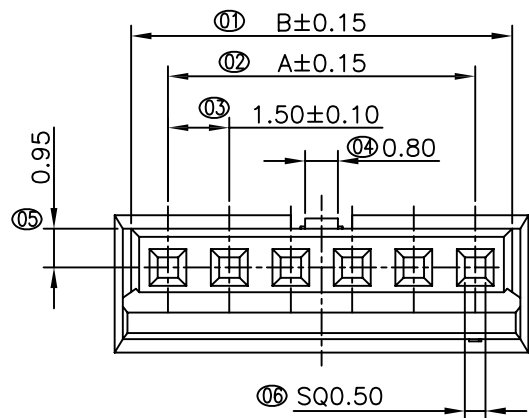

SPECIFICATIONS

- Voltage rating: 50V DC/AC (rms)
- Current rating: 1.0A
- Withstand voltage: 500V AC(rms)
- Working Temperature: -25°C +85°C
- Insulation resistance: ≥1000MΩ
- Contact resistance: ≤20MΩ

HOUSING

- PART NO: A1501H
- MATERIAL: NYLON66 94V-0
- COLOR: NATURAL(WHITE)
- USE WITH:
 - Terminal: A1501T
 - Wafer: A1501R A1501V
 - A1501RS A1501VS
- Q'TY: 1000PCS/BAG

poles	part no.	dimensions (mm)			
		A	B	C	D
2	A1501H-2P	1.50	3.30	3.70	4.10
3	A1501H-3P	3.00	4.80	5.20	5.60
4	A1501H-4P	4.50	6.30	6.70	7.10
5	A1501H-5P	6.00	7.80	8.20	8.60
6	A1501H-6P	7.50	9.30	9.70	10.10
7	A1501H-7P	9.00	10.80	11.20	11.60
8	A1501H-8P	10.50	12.30	12.70	13.10
9	A1501H-9P	12.00	13.80	14.20	14.60
10	A1501H-10P	13.50	15.30	15.70	16.10
11	A1501H-11P	15.00	16.80	17.20	17.60
12	A1501H-12P	16.50	18.30	18.70	19.10
13	A1501H-13P	18.00	19.80	20.20	20.60
14	A1501H-14P	19.50	21.30	21.70	22.10
15	A1501H-15P	21.00	22.80	23.20	23.60

MATERIAL: PA66UL94-V0	GENERAL TOLERANCE	
UNIT: MM	X. ±0.30	X.* ±2°
SCALE: 3:1	X.X ±0.25	X.X* ±1°
SIZE: A4	X.XX ±0.15	

YSTZ 东莞市轩盟电子科技有限公司
DONGGUAN YSTZ ELECTRONIC TECHNOLOGY CO.,LTD

PART NO: A1501H-NP-10E-01

TITLE : MX1.50MM PITCH HOUSING

REV: A	APPROVE	CHECK	DRAWN
SHEET:1/1	FENG	ZENG	LIJIAN

ROHS REACH

日期版次	日期	变更内容	核准
REVISION	DATE	DESCRIPTION	APPROVAL BY

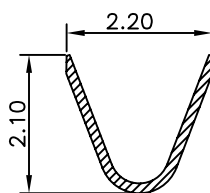
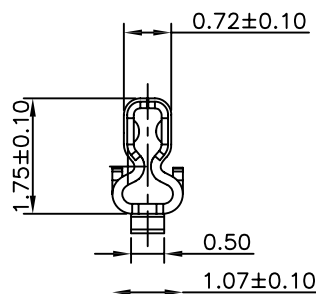
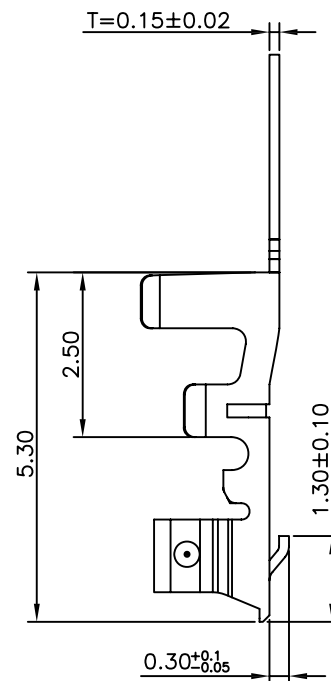
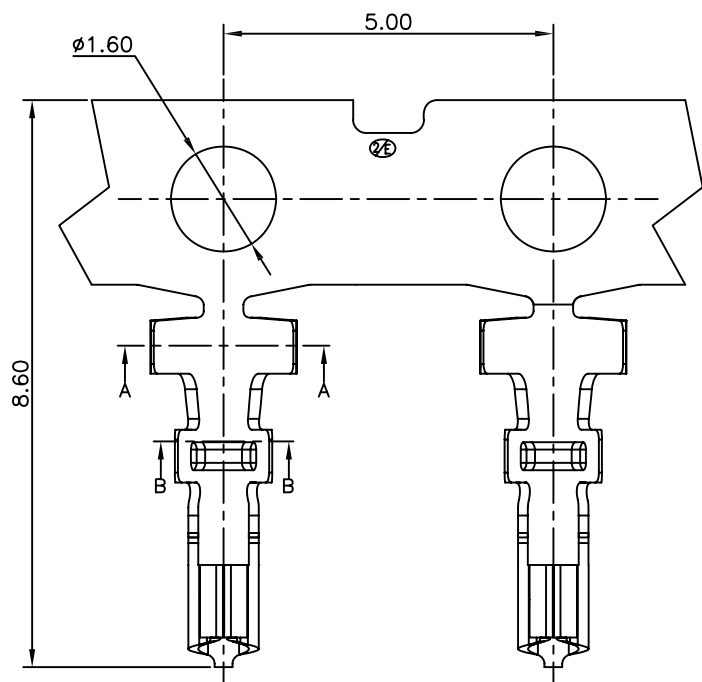

A-A SECTION

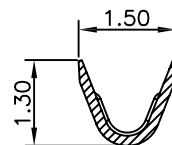

B-B SECTION

SPECIFICATIONS

- Voltage rating: 50V DC/AC (rms)
- Current rating: 1.0A
- Withstand voltage: 500V AC(rms)
- Working Temperature: -25°C+85°C
- Insulation resistance: ≥1000MΩ
- Contact resistance: ≤20mΩ

TERMINAL

- PART NO: A1501T
- THICKNESS: 0.15MM
- MATERIAL: PHOSPHOR BRONZE
- FINISH: TIN-PLATED
- APPLICABLE WIRE: AWG#24-#30
- USE WITH: Housing: A1501H
- Q'TY: 10000PCS/REEL

REV: A	APPROVE	CHECK	DRAWN
SHEET: 1/1	FENG	ZENG	LIJIAN

MATERIAL:	GENERAL TOLERANCE	
UNIT: MM	X. ±0.30	X.* ±2*
SCALE: 3:1	X.X ±0.25	X.X* ±1*
SIZE: A4	X.XX ±0.15	⊕ ⊖

YSTZ 东莞市轩盟电子科技有限公司
DONGGUAN YSTZ ELECTRONIC TECHNOLOGY CO.,LTD

PART NO: A1501T-PC-1E-01
TITLE: MX1.50mm Pitch Terminal

ROHS REACH

日期版次	日期	变更内容	核 准
REVISION	DATE	DESCRIPTION	APPROVALBY

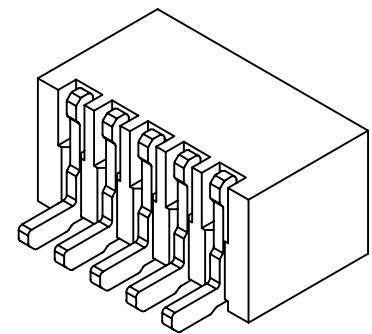
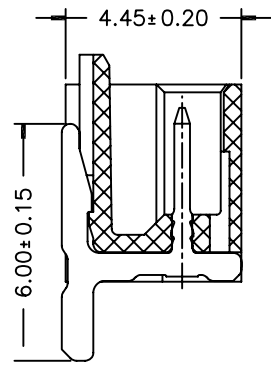
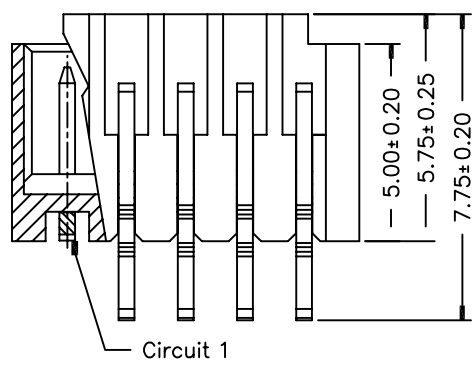

SPECIFICATIONS
 Current Rating: 3A AC,DC
 Voltage Rating: 350V AC,DC
 Temperature Range: -25°C ~ +85°C
 Contact Resistance: 20mΩ Max.
 Insulation Resistance: 1000MΩ Min.
 Withstanding Voltage: 500V AC/minute
 Pin Material: Brass/Tin-plated
 Material: Nylon 6T /LCP,UL94V-0
 Color: Natural(Beige)

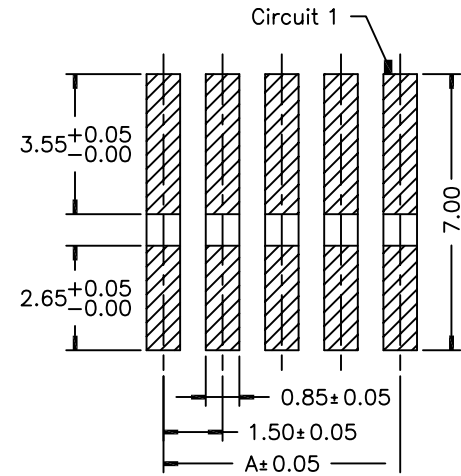
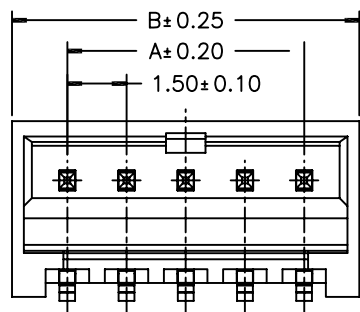

poles	part no	dimensions (mm)	
		A	B
2	A1501RS-2p	1.50	4.30
3	A1501RS-3p	3.00	5.80
4	A1501RS-4p	4.50	7.30
5	A1501R-5p	6.00	8.80
6	A1501RS-6p	7.50	10.30
7	A1501RS-7p	9.00	11.80
8	A1501RS-8p	10.50	13.30
9	A1501RS-9p	12.00	14.80
10	A1501RS-10p	13.50	16.30
11	A1501RS-11p	15.00	17.80
12	A1501RS-12p	16.50	19.30
13	A1501RS-13p	18.00	20.80
14	A1501RS-14p	19.50	22.30
15	A1501RS-15p	21.00	23.80

PIN针	BRASS	NICHEL30-50U*
定位片	BRASS	HIGH TEMPERATURE WHDLE TIN70-120U* 3#
壳体	PA6T UL 94V-0	MATURE

PART NAME	PART NO.	MATERIALS	SPEC
REV: A	APPROVE	CHECK	DRAWN
SHEET:1/1	FENG	ZENG	LIJIAN

MATERIAL: PA66UL94-V0	GENERAL TOLERANCE
UNIT: MM	X. ±0.30 X.* ±2°
SCALE: 3:1	X.X ±0.25 X.X* ±1°
SIZE: A4	X.XX ±0.15

YSTZ 东莞市轩盟电子科技有限公司
 DONGGUAN YSTZ ELECTRONIC TECHNOLOGY CO.,LTD

PART NO: A1501RS-NP-30E-01

TITLE : 1.5MM PITCH 90°WAFER-SMT-TYPE