

ROHS REACH

日期版次	日期	变更内容	核 准
REVISION	DATE	DESCRIPTION	APPROVALBY

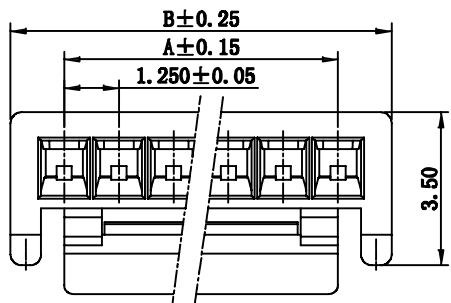

4PIN、6PIN

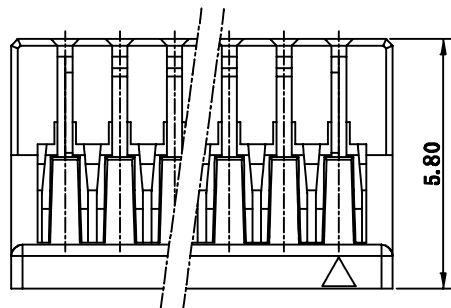
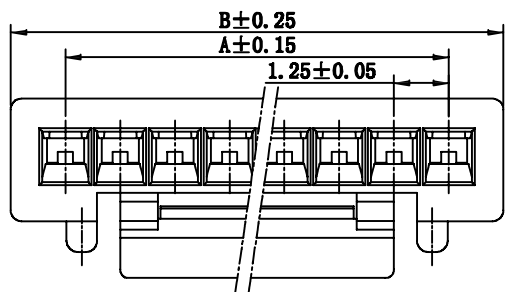

8PIN 以上

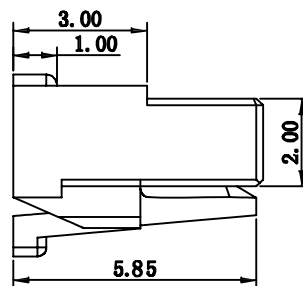
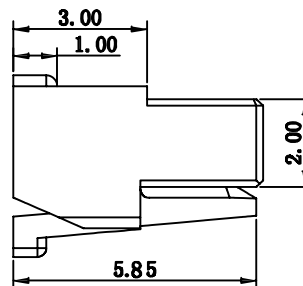

SPECIFICATIONS

- Voltage rating: 200V DC/AC (rms)
- Current rating: 1.0A
- Withstand voltage: 500V AC(rms)
- Working Temperature: -25℃+85℃
- Insulation resistance: ≥100MΩ
- Contact resistance: ≤20MΩ

HOUSING

- PART NO: A1257H
- MATERIAL: PA66+15%GF 94V-0
- COLOR: NATURAL(WHITE)
- USE WITH:  
Terminal: A1257T  
Wafer: A1257R    A1257V
- Q'TY: 1000PCS/BAG

poles	part no.	dimensions (mm)	
		A	B
2	A1257H-2P	1.25	3.60
3	A1257H-3P	2.50	4.85
4	A1257H-4P	3.75	6.10
5	A1257H-5P	5.00	7.35
6	A1257H-6P	6.25	8.60
7	A1257H-7P	7.50	9.85
8	A1257H-8P	8.75	11.10
9	A1257H-9P	10.00	12.35
10	A1257H-10P	11.25	13.60
11	A1257H-11P	12.50	14.85
12	A1257H-12P	13.75	16.10
13	A1257H-13P	15.00	17.35
14	A1257H-14P	16.25	18.60
15	A1257H-15P	17.50	19.85

MATERIAL: PA66UL94-V0	GENERAL TOLERANCE	
UNIT: MM	X. ±0.30	X.* ±2°
SCALE: 3:1	X.X ±0.25	X.X* ±1°
SIZE: A4	X.XX ±0.15	

**YSTZ** 东莞市轩盟电子科技有限公司  
DONGGUAN YSTZ ELECTRONIC TECHNOLOGY CO.,LTD

PART NO: A1257H-NP-10E-02

TITLE : GH1.25MM PITCH HOUSING

REV: A	APPROVE	CHECK	DRAWN
SHEET:1/1	FENG	ZENG	LIJIAN

ROHS REACH

日期版次 REVISION	日期 DATE	变更内容 DESCRIPTION	核 准 APPROVALBY

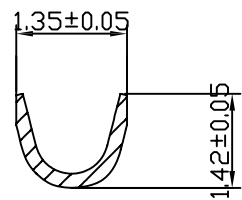
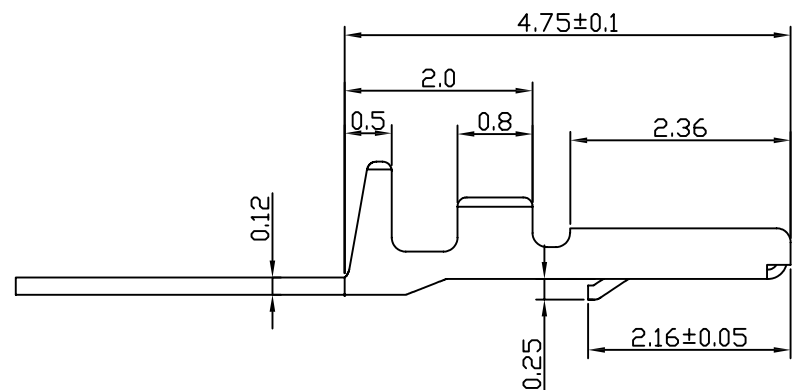
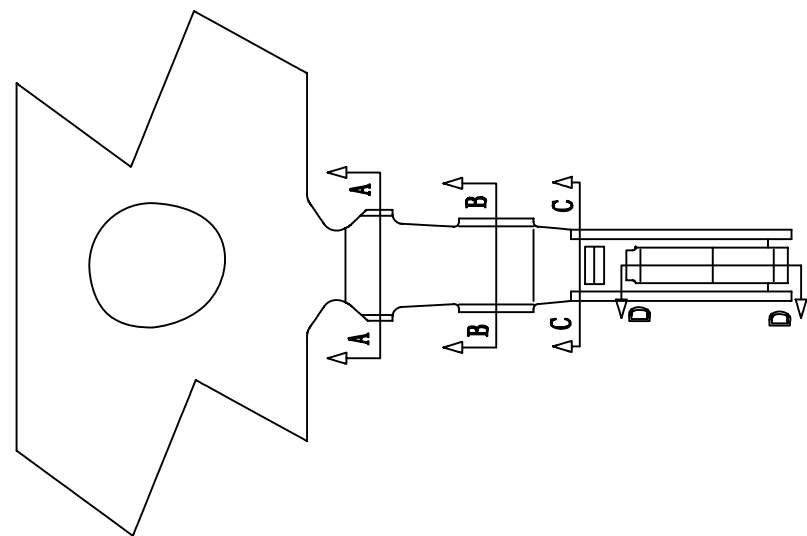

SECTION: A-A

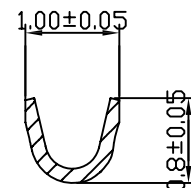

SECTION: B-B

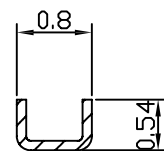

SECTION: C-C

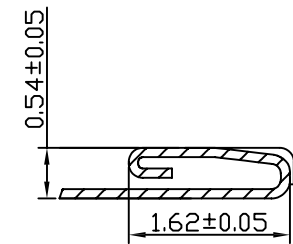

SECTION: D-D

SPECIFICATIONS

- Voltage rating: 50V DC/AC (rms)
- Current rating: 1.0A
- Withstand voltage: 500V AC(rms)
- Working Temperature: -25°C+85°C
- Insulation resistance: ≥100MΩ
- Contact resistance: ≤20mΩ

TERMINAL

- PART NO: A1257T
- THICKNESS: 0.12MM
- MATERIAL: PHOSPHOR BRONZE
- FINISH: TIN-PLATED
- APPLICABLE WIRE: AWG#28-#32
- USE WITH: Housing: A1257H
- Q'TY: 15000PCS/REEL

REV: A	APPROVE	CHECK	DRAWN	MATERIAL:	GENERAL TOLERANCE		东莞市轩盟电子科技有限公司 DONGGUAN YSTZ ELECTRONIC TECHNOLOGY CO.,LTD
	FENG	ZENG	LIJIAN	UNIT: MM	X. ±0.30	X.* ±2*	
	SHEET: 1/1			SCALE: 3:1	X.X ±0.25	X.X* ±1*	
				SIZE: A4	X.XX ±0.15		PART NO: A1257T-PC-1E-02
							TITLE: GH1.25mm Pitch Terminal

# ROHS REACH

日期版次	日期	变更内容	核 准
REVISION	DATE	DESCRIPTION	APPROVALBY

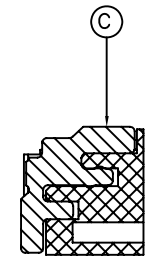
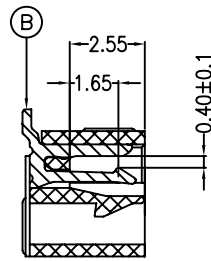
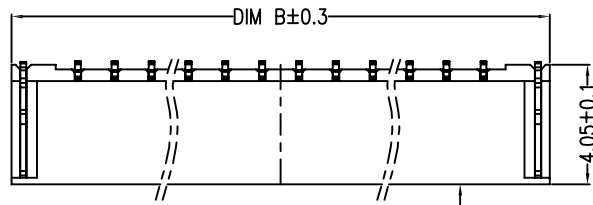

SECTION B-B

SECTION A-A

### SPECIFICATIONS

- Voltage rating: 50V DC/AC (rms)
- Current rating: 1.0A
- Withstand voltage: 500V AC(rms)
- Working Temperature: -25°C +85°C
- Insulation resistance: ≥100MΩ
- Contact resistance: ≤20MΩ

### WAFER:

- PART NO: A1257VS
- MATERIAL: LCP 94V-0
- COLOR: BEIGE
- USE WITH:  
HOUSING: A1257H

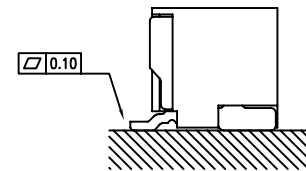
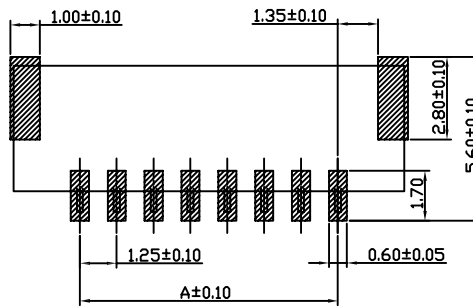
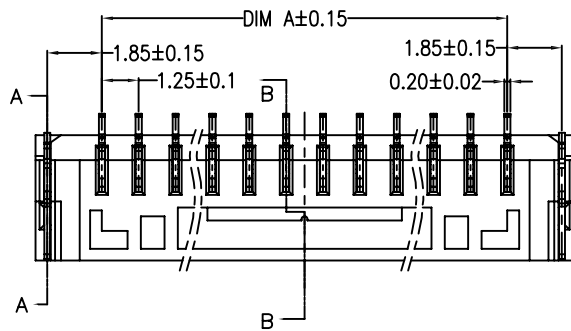
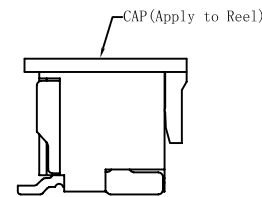
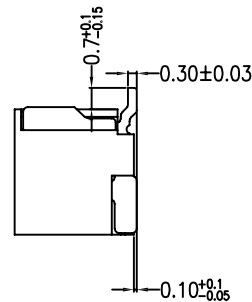
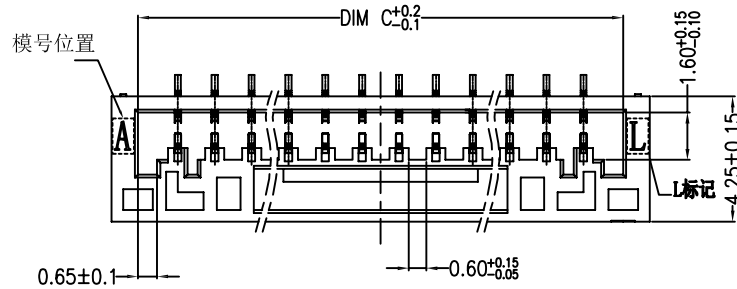

pole s	part no.	dimensions (mm)		
		A	B	C
2	1257VS-2P	1.25	5.75	3.95
3	1257VS-3P	2.50	7.00	5.20
4	1257VS-4P	3.75	8.25	6.45
5	1257VS-5P	5.00	9.50	7.70
6	1257VS-6P	6.25	10.75	8.95
7	1257VS-7P	7.50	12.00	10.20
8	1257VS-8P	8.75	13.25	11.45
9	1257VS-9P	10.00	14.50	12.70
10	1257VS-10P	11.25	15.75	13.95
11	1257VS-11P	12.50	17.00	15.20
12	1257VS-12P	13.75	18.25	16.45
13	1257VS-13P	15.00	19.50	17.70
14	1257VS-14P	16.25	20.75	18.95
15	1257VS-15P	17.50	22.00	20.20

定位片	2	PHOSPHORBRONZE	TIN-PLATED
PIN针	2--16	PHOSPHORBRONZE	TIN-PLATED
壳体	1	PA46 UL 94V-0	BEIGE
PART NAME	PART NO.	MATERIALS	SPEC

MATERIAL:	GENERAL TOLERANCE
UNIT: MM	X. ±0.30 X.* ±2°
SCALE: 3:1	X.X ±0.25 X.X* ±1°
SIZE: A4	X.XX ±0.15

**YSTZ 东莞市轩盟电子科技有限公司**  
DONGGUAN YSTZ ELECTRONIC TECHNOLOGY CO.,LTD

PART NO: A1257VS-NP-50E-25

TITLE: GH1.25MM PITCH 立式 WAFER

REV: A	APPROVE	CHECK	DRAWN
SHEET:1/1	FENG	ZENG	LIJIAN

# ROHS REACH

日期版次 REVISION	日期 DATE	变更内容 DESCRIPTION	核 准 APPROVALBY

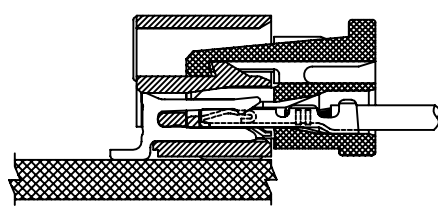
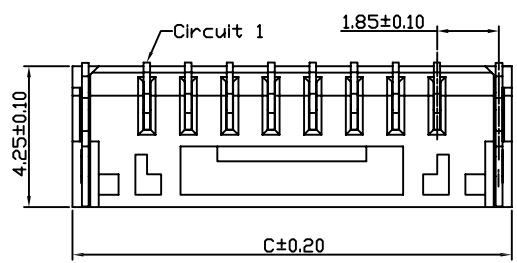

Assembly Layout

### SPECIFICATIONS

- Voltage rating: 50V DC/AC (rms)
- Current rating: 1.0A
- Withstand voltage: 500V AC(rms)
- Working Temperature: -25℃ +85℃
- Insulation resistance: ≥100MΩ
- Contact resistance: ≤20MΩ

### WAFER:

- PART NO: A1257RS
- MATERIAL: LCP 94V-0
- COLOR: BEIGE
- USE WITH:  
HOUSING: A1257H

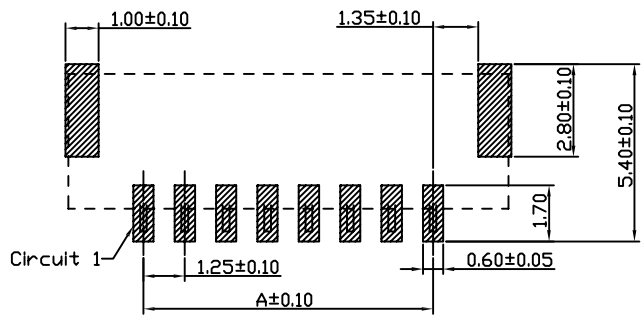
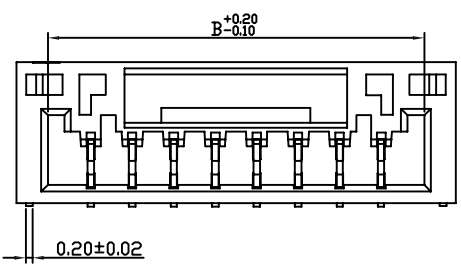
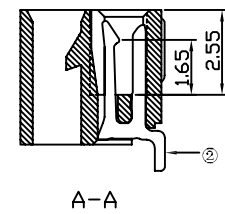
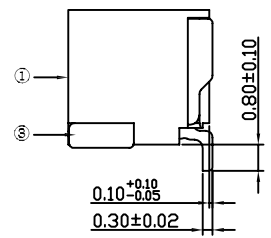
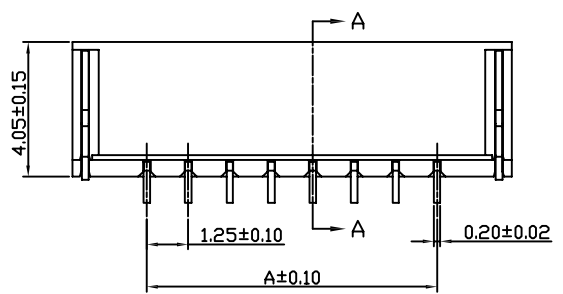

SUGGESTED PCB LAYOUT  
(COMPONENT SIDE)

pole s	part no.	dimensions (mm)		
		A	B	C
2	1257RS-2P	1.25	3.85	5.75
3	1257RS-3P	2.50	5.10	7.00
4	1257RS-4P	3.75	6.35	8.25
5	1257RS-5P	5.00	7.60	9.50
6	1257RS-6P	6.25	8.85	10.75
7	1257RS-7P	7.50	10.10	12.00
8	1257RS-8P	8.75	11.35	13.25
9	1257RS-9P	10.00	12.60	14.50
10	1257RS-10P	11.25	13.85	15.75
11	1257RS-11P	12.50	15.10	17.00
12	1257RS-12P	13.75	16.35	18.25
13	1257RS-13P	15.00	17.60	19.50
14	1257RS-14P	16.25	18.85	20.75
15	1257RS-15P	17.50	20.10	22.00

定位片	2	PHOSPHORBRONZE	TIN-PLATED
PIN针	2--16	PHOSPHORBRONZE	TIN-PLATED
壳体	1	LCP UL 94V-0	BEIGE
PART NAME	PART NO.	MATERIALS	SPEC
REV: A	APPROVE	CHECK	DRAWN
SHEET:1/1	FENG	ZENG	LIJIAN

MATERIAL:	GENERAL TOLERANCE
UNIT: MM	X. ±0.30 X.* ±2°
SCALE: 3:1	X.X ±0.25 X.X* ±1°
SIZE: A4	X.XX ±0.15

**YSTZ** 东莞市轩盟电子科技有限公司  
DONGGUAN YSTZ ELECTRONIC TECHNOLOGY CO.,LTD

PART NO: A1257RS-NP-50E-25

TITLE : GH1.25MM PITCH 卧式 WAFER