

ROHS REACH

日期版次	日期	变更内容	核 准
REVISION	DATE	DESCRIPTION	APPROVALBY

SPECIFICATIONS

- Voltage rating: 100V DC/AC (rms)
- Current rating: 1.5A
- Withstand voltage: 800V AC(rms)
- Working Temperature: -25°C +85°C
- Insulation resistance: ≥100MΩ
- Contact resistance: ≤20MΩ

HOUSING

- PART NO: A1251H
- MATERIAL: PA66+15%GF 94V-0
- COLOR: BROWN
- USE WITH:
 - Terminal: A1251T
 - Wafer: A1251R A1251V
- Q'TY: 1000PCS/BAG

poles	part no.	dimensions (mm)	
		A	B
2	A1251H-2P	1.25	3.95
3	A1251H-3P	2.50	5.20
4	A1251H-4P	3.75	6.45
5	A1251H-5P	5.00	7.70
6	A1251H-6P	6.25	8.95
7	A1251H-7P	7.50	10.20
8	A1251H-8P	8.75	11.45
9	A1251H-9P	10.00	12.70
10	A1251H-10P	11.25	13.95
11	A1251H-11P	12.50	15.20
12	A1251H-12P	13.75	16.45
13	A1251H-13P	15.00	17.70
14	A1251H-14P	16.25	18.95
15	A1251H-15P	17.50	20.20

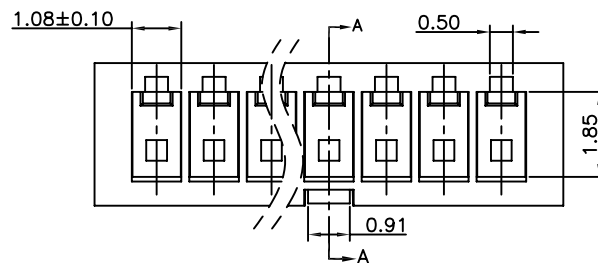
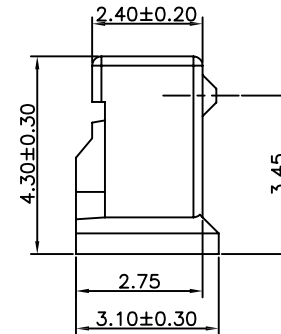
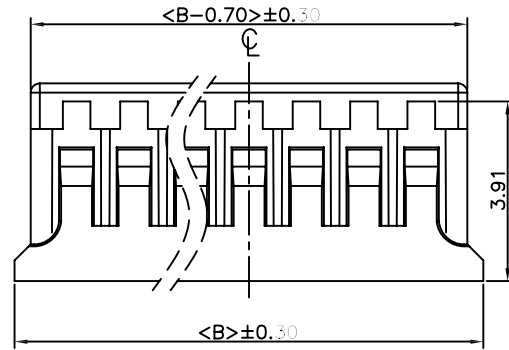
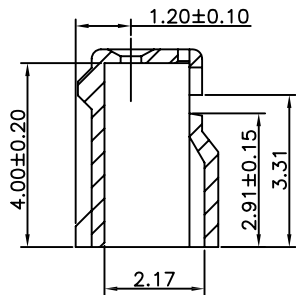
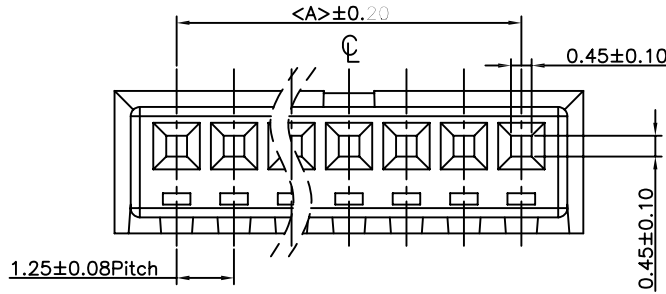

MATERIAL:
PA66UL94-V0

GENERAL TOLERANCE

YSTZ 东莞市轩盟电子科技有限公司
DONGGUAN YSTZ ELECTRONIC TECHNOLOGY CO.,LTD

REV: A	APPROVE	CHECK	DRAWN
SHEET:1/1	FENG	ZENG	LIJIAN

UNIT: MM	X. ±0.30	X.* ±2°
SCALE: 3:1	X.X ±0.25	X.X* ±1°
SIZE: A4	X.XX ±0.15	

PART NO: A1251H-NP-14E-01

TITLE : JAE1.25MM PITCH HOUSING

ROHS REACH

日期版次	日期	变更内容	核 准
REVISION	DATE	DESCRIPTION	APPROVALBY

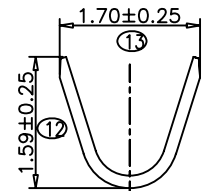
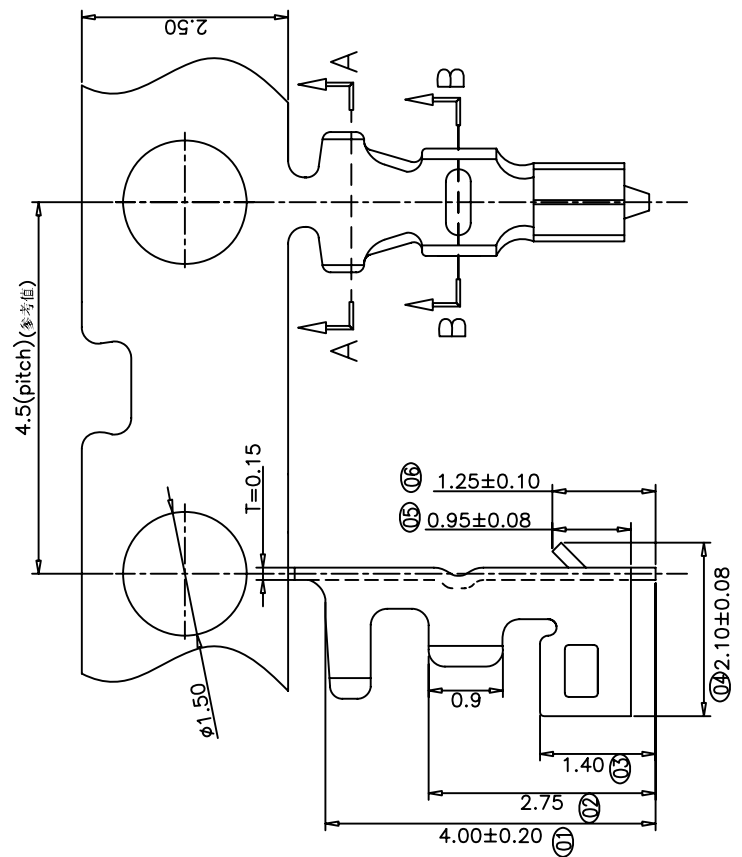

SECTION:A-A
SCALE 1:1

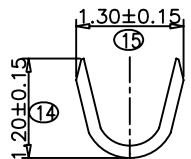

SECTION:B-B
SCALE 1:1

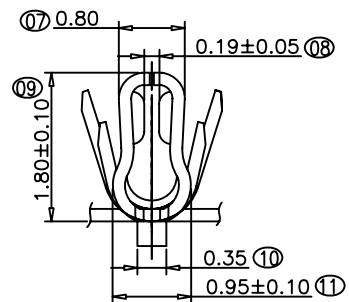

SPECIFICATIONS

- Voltage rating: 100V DC/AC (rms)
- Current rating: 1.5A
- Withstand voltage: 800V AC(rms)
- Working Temperature: -25°C +85°C
- Insulation resistance: ≥100MΩ
- Contact resistance: ≤20mΩ

TERMINAL

- PART NO: A1251T
- THICKNESS: 0.15MM
- MATERIAL: PHOSPHOR BRONZE
- FINISH: TIN-PLATED
- APPLICABLE WIRE: AWG#28-#32
- USE WITH: Housing: A1251H
- Q'TY: 10000PCS/REEL

REV: A	APPROVE	CHECK	DRAWN
SHEET: 1/1	FENG	ZENG	LIJIAN

MATERIAL:	GENERAL TOLERANCE	
UNIT: MM	X. ±0.30	X.* ±2°
SCALE: 3:1	X.X ±0.25	X.X* ±1°
SIZE: A4	X.XX ±0.15	⊕ ⊖

YSTZ 东莞市轩盟电子科技有限公司
DONGGUAN YSTZ ELECTRONIC TECHNOLOGY CO.,LTD

PART NO: A1251T-PC-1E-01

TITLE : JAE1.25mm Pitch Terminal

ROHS REACH

日期版次	日期	变更内容	核 准
REVISION	DATE	DESCRIPTION	APPROVALBY

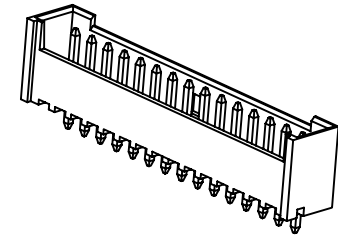
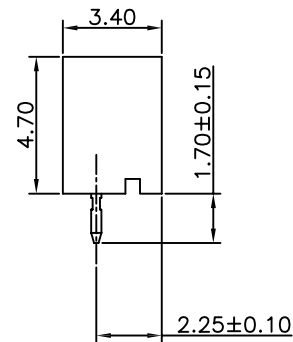
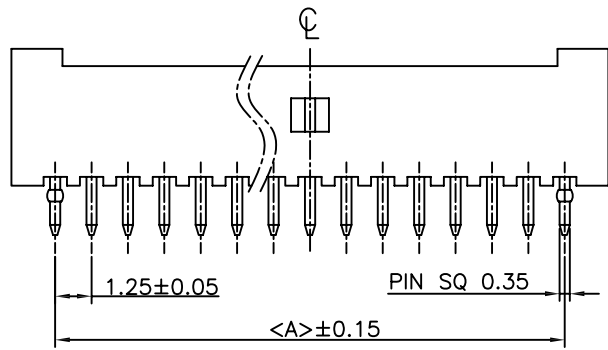

SPECIFICATIONS

- Voltage rating: 100V DC/AC (rms)
- Current rating: 1.5A
- Withstand voltage: 800V AC(rms)
- Working Temperature: -25°C +85°C
- Insulation resistance: ≥100MΩ
- Contact resistance: ≤20mΩ

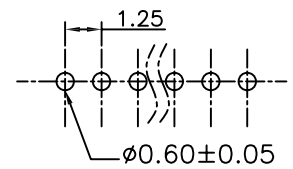
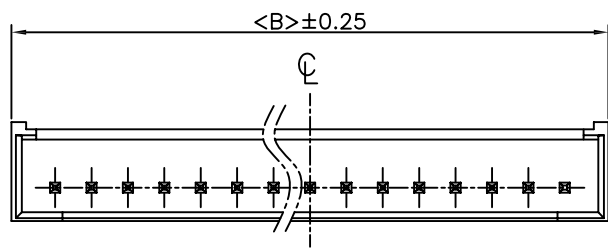

RECOMMENDED P.C.B LAYOUT (TOP SIDE)
P.C.B THICKNESS = 0.8mm (TOLERANCE=±0.05)

poles	part no	dimensions (mm)	
		A	B
2	A1251V-2P	1.25	4.25
3	A1251V-3P	2.50	5.50
4	A1251V-4P	3.75	6.75
5	A1251V-5P	5.00	8.00
6	A1251V-6P	6.25	9.25
7	A1251V-7P	7.50	10.50
8	A1251V-8P	8.75	11.75
9	A1251V-9P	10.00	13.00
10	A1251V-10P	11.25	14.25
11	A1251V-11P	12.50	15.50
12	A1251V-12P	13.75	16.75
13	A1251V-13P	15.00	18.00
14	A1251V-14P	16.25	19.25
15	A1251V-15P	17.50	20.50

PIN针	2--15	BRASS	HIGH TEMPERATURE WHDLE TIN
壳体	1	PA66+15%GF UL 94V-0	MATURE
PART NAME	PART NO.	MATERIALS	SPEC
REV: A	APPROVE	CHECK	DRAWN
SHEET:1/1	FENG	ZENG	LIJIAN

MATERIAL:	GENERAL TOLERANCE	
UNIT: MM	X. ±0.30	X.* ±2°
SCALE: 3:1	X.X ±0.25	X.X* ±1°
SIZE: A4	X.XX ±0.15	⊕ ⊖

YSTZ 东莞市轩盟电子科技有限公司
DONGGUAN YSTZ ELECTRONIC TECHNOLOGY CO.,LTD

PART NO: A1251V-NP-14E-01

TITLE : JAE1.25mm Pitch 180°-Wafer

ROHS REACH

日期版次 REVISION	日期 DATE	变更内容 DESCRIPTION	核 准 APPROVALBY

SPECIFICATIONS

- Voltage rating: 100V DC/AC (rms)
- Current rating: 1.5A
- Withstand voltage: 800V AC(rms)
- Working Temperature: -25°C +85°C
- Insulation resistance: ≥100MΩ
- Contact resistance: ≤20mΩ

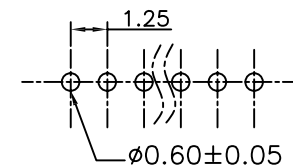
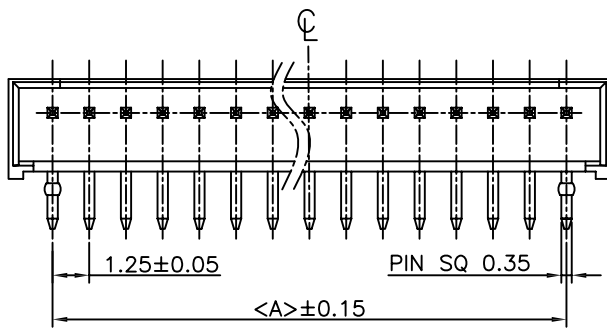
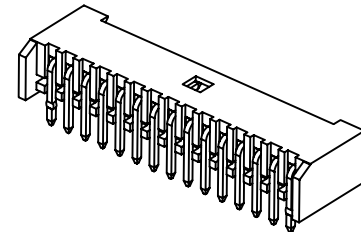
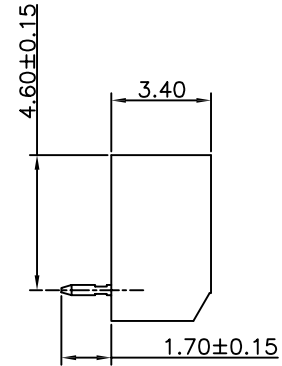
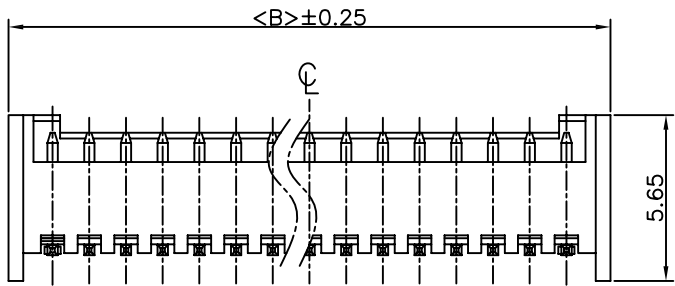

RECOMMENDED P.C.B LAYOUT (TOP SIDE)
P.C.B THICKNESS = 0.8mm (TOLERANCE=±0.05)

poles	part no	dimensions (mm)	
		A	B
2	A1251R-2P	1.25	4.25
3	A1251R-3P	2.50	5.50
4	A1251R-4P	3.75	6.75
5	A1251R-5P	5.00	8.00
6	A1251R-6P	6.25	9.25
7	A1251R-7P	7.50	10.50
8	A1251R-8P	8.75	11.75
9	A1251R-9P	10.00	13.00
10	A1251R-10P	11.25	14.25
11	A1251R-11P	12.50	15.50
12	A1251R-12P	13.75	16.75
13	A1251R-13P	15.00	18.00
14	A1251R-14P	16.25	19.25
15	A1251R-15P	17.50	20.50

PIN针	2--15	BRASS	HIGH TEMPERATURE WHDLE TIN
壳体	1	PA66+15%GF UL 94V-0	MATURE
PART NAME	PART NO.	MATERIALS	SPEC
REV: A	APPROVE	CHECK	DRAWN
SHEET:1/1	FENG	ZENG	LIJIAN

MATERIAL:	GENERAL TOLERANCE	
UNIT: MM	X. ±0.30	X.* ±2°
SCALE: 3:1	X.X ±0.25	X.X* ±1°
SIZE: A4	X.XX ±0.15	⊕ ⊖

YSTZ 东莞市轩盟电子科技有限公司
DONGGUAN YSTZ ELECTRONIC TECHNOLOGY CO.,LTD

PART NO: A1251R-NP-14E-01

TITLE : JAE1.25mm Pitch 90°-Wafer